

ASSEMBLY INSTRUCTIONS









MODEL : ENZO RECT.BAR TABLE

IMPORTANT NOTE :

* PLACE ALL WOODEN PARTS ON A CLEAN AND SMOOTH SURFACE SUCH AS A RUG OR CARPET TO AVOID THE PARTS FROM BEING SCRATCHED.

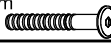
* BEFORE YOU BEGIN, KINDLY FOLLOW THE ASSEMBLY INSTRUCTIONS STEP BY STEP.

HARDWARE LIST

A	JCBB SCREW M8 x 70mm		8PCS
B	SPRING WASHER 5/16"		8PCS
C	FLAT WASHER 5/16"		8PCS
D	ALLEN KEY M5		1PC
E	JCBC SCREW M6 x 45mm		2PCS
F	SPRING WASHER M6		2PCS
G	FLAT WASHER M6		2PCS
H	ALLEN KEY M4		1PC
I	FH SCREW #8 x 32mm		4PCS

PART LIST

1	TABLE TOP	1PC
2	TABLE LEG	4PCS
3	SIDE STRETCHER	2PCS
4	CROSS BAR	1PC

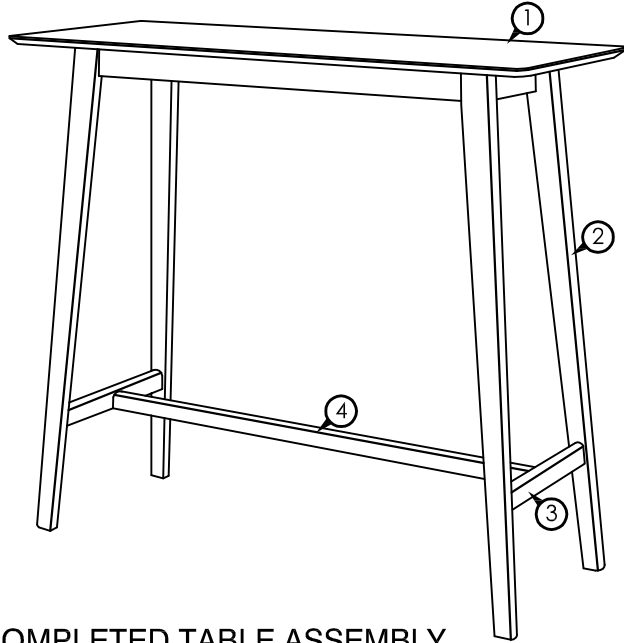

COMPLETED TABLE ASSEMBLY.

STEP 1

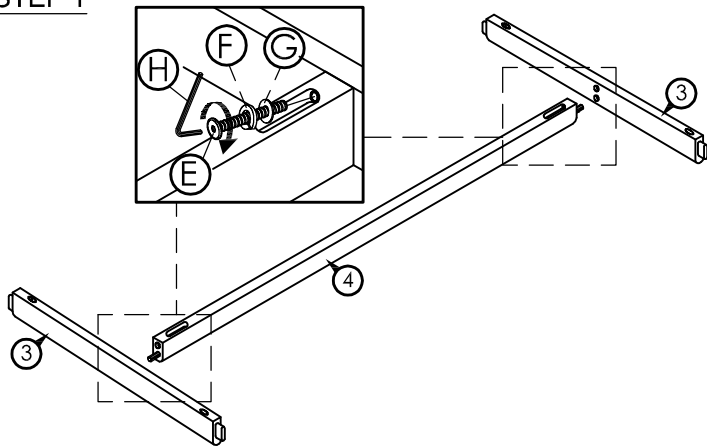

STEP 2

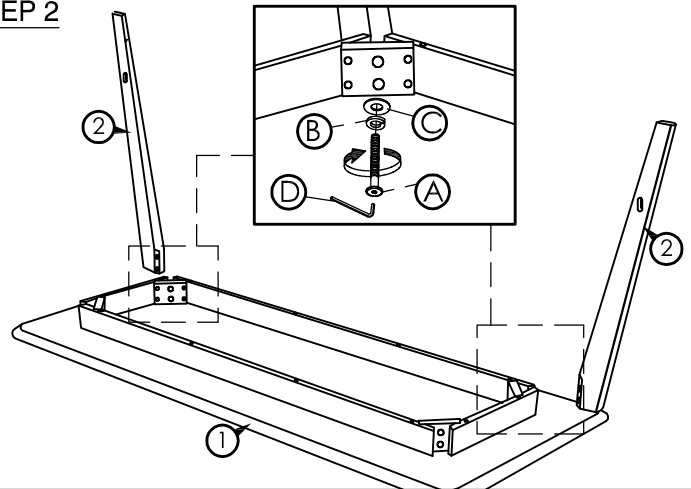

STEP 3

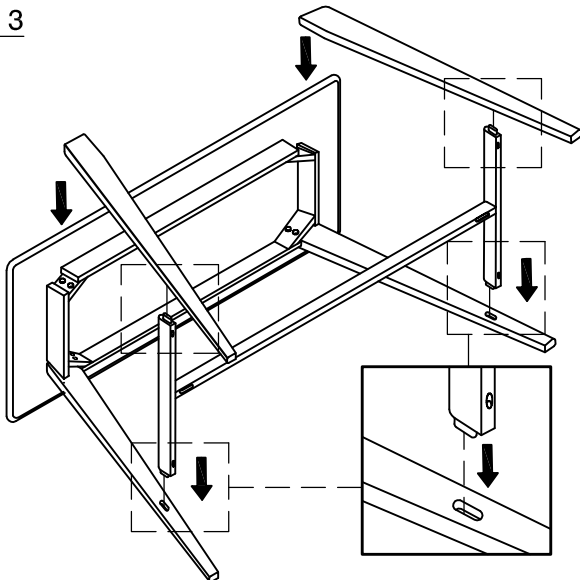

STEP 4

