







ASSEMBLY INSTRUCTIONS

MODEL : ENZO ROUND BAR TABLE

IMPORTANT NOTE :

- * PLACE ALL WOODEN PARTS ON A CLEAN AND SMOOTH SURFACE SUCH AS A RUG OR CARPET TO AVOID THE PARTS FROM BEING SCRATCHED.
- * BEFORE YOU BEGIN, KINDLY FOLLOW THE ASSEMBLY INSTRUCTIONS STEP BY STEP.

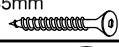
HARDWARE LIST

A	JCBB SCREW M8 x 80mm 	8PCS
B	SPRING WASHER 5/16" 	8PCS
C	FLAT WASHER 5/16" 	8PCS
D	ALLEN KEY M5 	1PC
E	JCBC W SCREW M7 x 35mm 	1PC
F	ALLEN KEY M4 	1PC
G	CSK SCREW M4 x 38mm 	4PCS

PART LIST

1	TABLE TOP	1PC
2	TABLE LEG	4PCS
3	CROSS BAR	2PCS

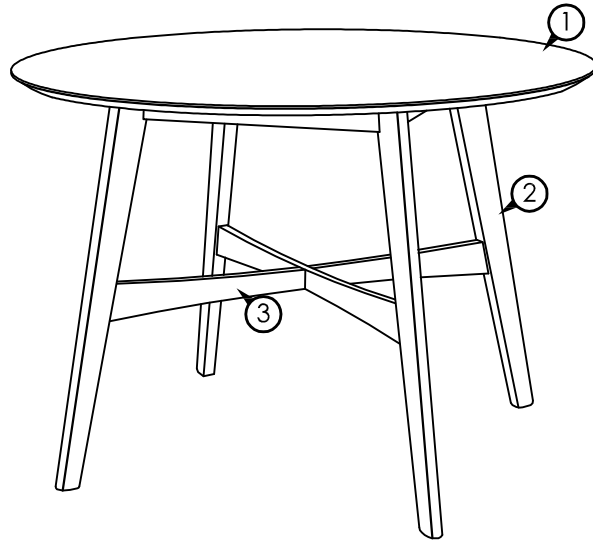

COMPLETED TABLE ASSEMBLY.

STEP 1

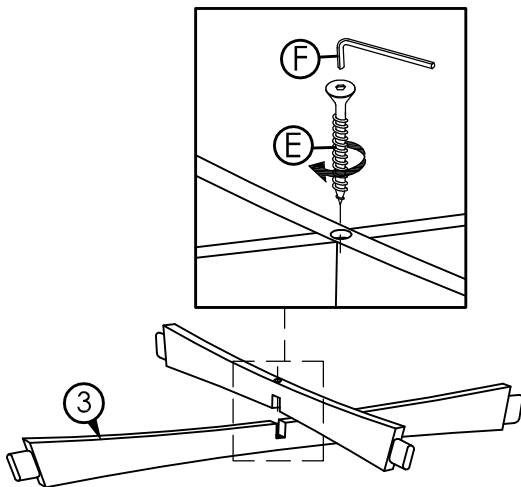

STEP 2

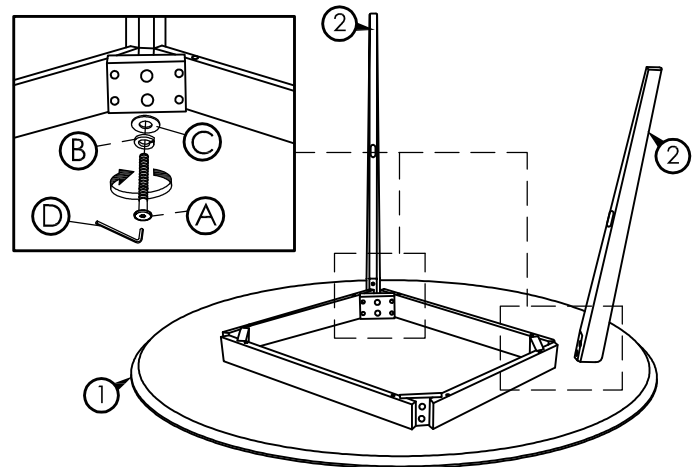

* DO NOT FULLY TIGHTEN ALL THE BOLT NOW

STEP 3

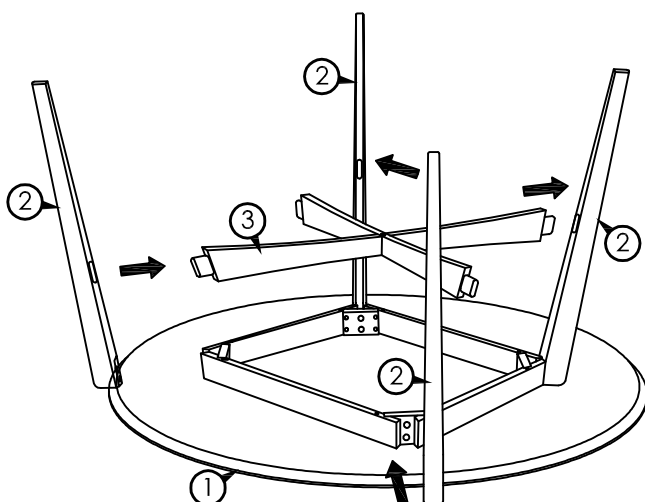

STEP 4

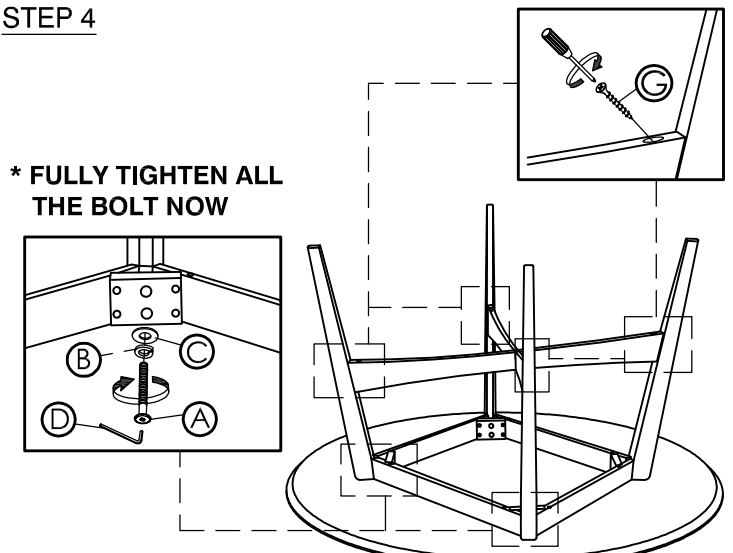

* FULLY TIGHTEN ALL THE BOLT NOW