

# Assembly Instructions

## PADDINGTON

### Dining Table

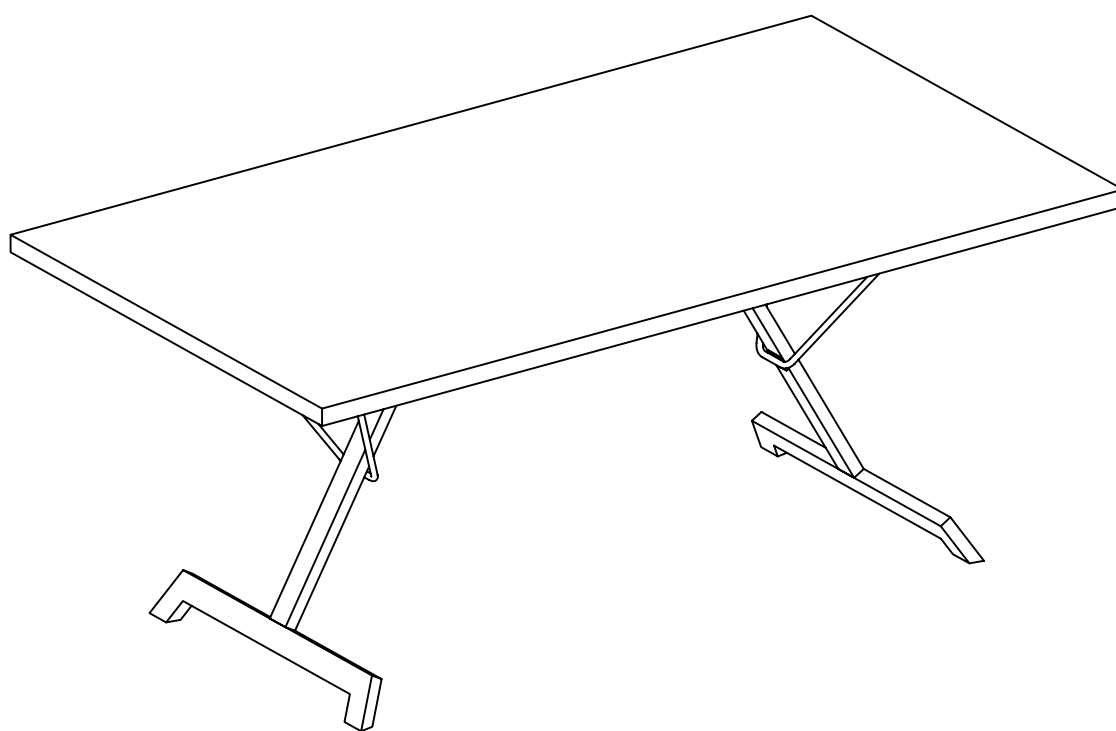

# WARNING

FAILURE TO FOLLOW THESE BASIC STEPS CAN LEAD TO DAMAGE THAT IS NOT COVERED BY YOUR WARRANTY

1



Read Instructions carefully. Check no parts are missing.

2

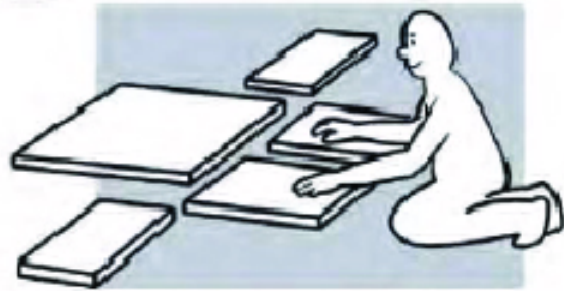

Lay out all of the components on a soft surface as if you were preparing to do a jigsaw puzzle.

3



Carefully identify each component, especially those that are similar. The most common mistake is getting things back to front.

4



Separate and identify each component from the hardware pack and rest each one in its proper location before fastening.

5



**DO NOT** fully tighten screws (leave slightly loose). When the item is fully assembled tighten the screws - but do not over tighten.

6



If glue is required **DO NOT** set until you are certain that the parts belong together.

# WHAT YOU NEED

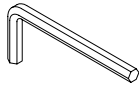

1 x ALLEN KEY(5MM)  
(PROVIDED)

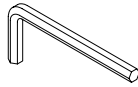

1 x ALLEN KEY(4MM)  
(PROVIDED)

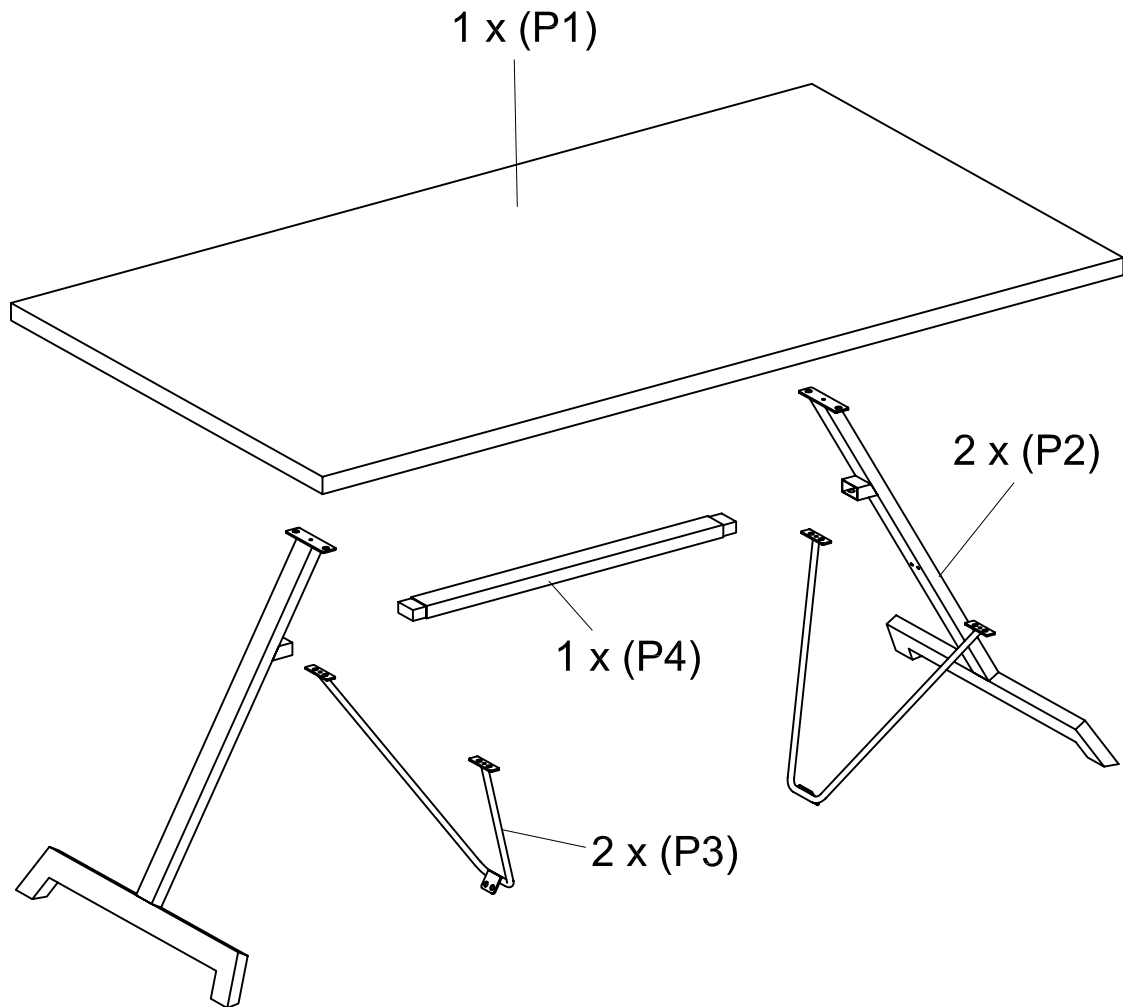

8 x SCREWS(16mm)  
(H1)



8 x SCREWS(20mm)  
(H2)



16 x WASHER  
(H3)





4 x SCREWS(25mm)  
(H4)



4 x WASHER  
(H5)

## STEP 1

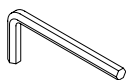

YOU WILL NEED:	
4 x H1	16mm 
4 x H3	

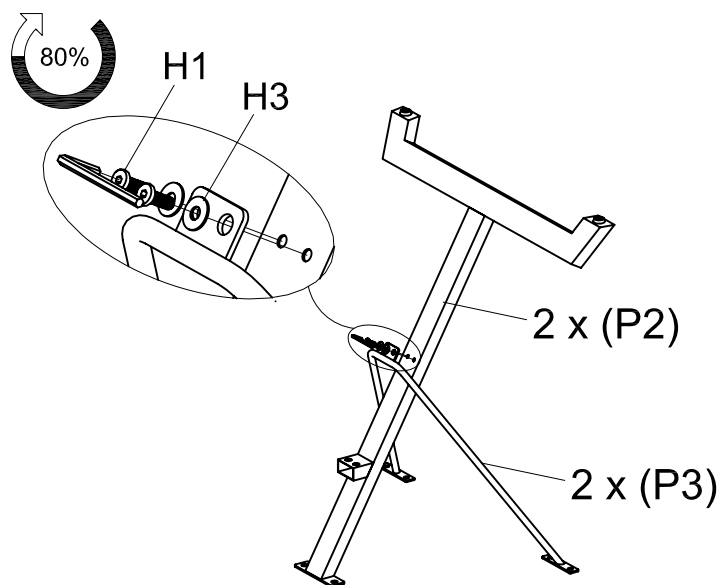

1 x ALLEN KEY(4MM)  
(PROVIDED)



## STEP 2



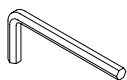

YOU WILL NEED:	
4 x H1	16mm 
4 x H3	

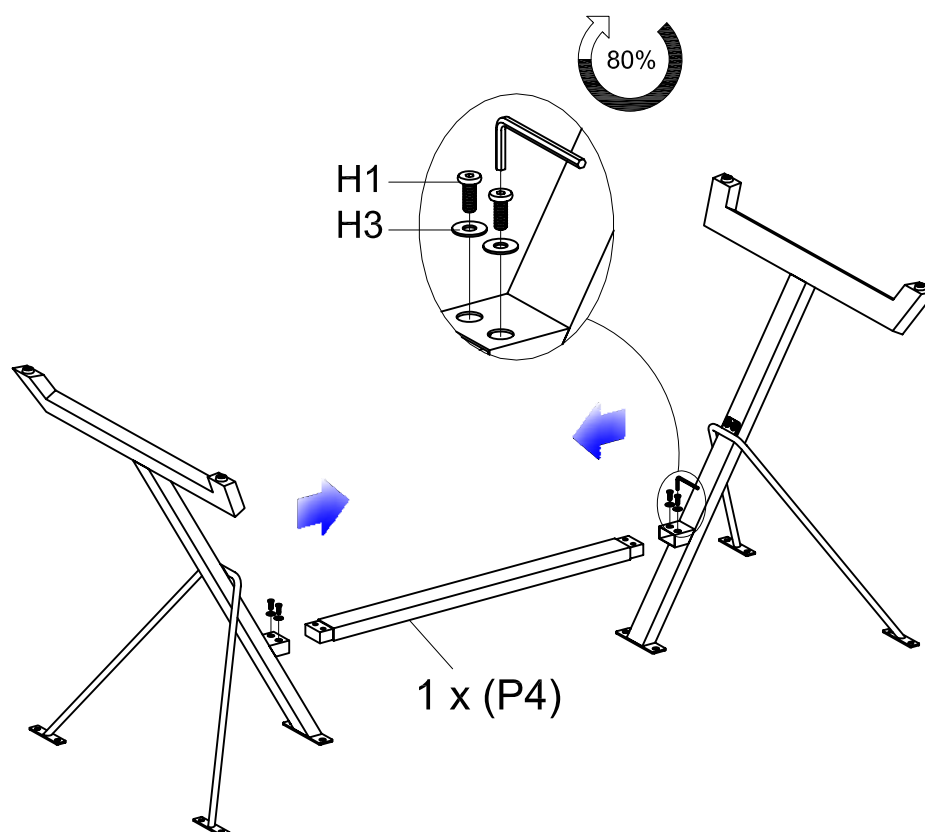

1 x ALLEN KEY(4MM)  
(PROVIDED)



### STEP 3

YOU WILL NEED:	
8 x H2	20mm 
8 x H3	
4 x H4	25mm 
4 x H5	



1 x ALLEN KEY(5MM)  
(PROVIDED)

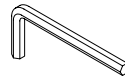

1 x ALLEN KEY(4MM)  
(PROVIDED)

